

TABLE OF CONTENTS

1. Safety precautions and warnings
2. General information
 - 2.1 Machine description
 - 2.2 Machine characteristics
3. Product packaging checklish
4. Overview
 - 4.1 Specification
 - 4.2 Software overview
 - 4.2.1 Introduction
 - 4.2.2 Smart phone operation system
 - 4.2.3 Software update
5. Installation
 - 5.1 Install APP
 - 5.2 Cutter and probe installation
 - 5.3 Clamp Introduction
 - 5.4 Super key blank
 - 5.5 Operation instructions on APP
 - 5.5.1 Install cutter & probe
 - 5.5.2 Calibration
 - 5.5.3 Cut by bitting
 - 5.5.4 All key lost
 - 5.5.5 Find bitting
 - 5.5.6 Generate key type
 - 5.5.7 Create keys by camera
 - 5.5.8 Customize key data
 - 5.5.9 Universal key duplicate
 - 5.6 Online update
 - 5.7 Maintenance
 - 5.8 Warranty and after sales description

1. Safety precautions and warnings

To avoid injuries to operators and damages to machines, please read this product user manual carefully before you start and follow the safety notes listed below:

- Always use the machine under safe environment
- Wear protective goggles that are in line with ANSI standard
- Leave from away when the machine is working
- Do not have clothes, hair, hands and other tools close to the machine when it is working
- Do not leave the machine unattended when it is working
- Do not use a damaged or loose socket
- Unplug the machine when it is not in use for a long time
- Do not place the machine in a place that is damp, greasy and dusty
- Do not put things like tool or containers on the machine
- Put the machine on a flat and firm surface
- Keep the machine dry and clean
- Unplug the machine instantly under unusual circumstance

2. General information

2.1 Machine description

Dear customers, thank you for choosing 2M2 TANK portable automatic key cutting machine. 2M2 TANK is a portable machine, with a small volume and light weight, is particularly and carefully designed for locksmiths worldwide. This product user manual provides operating instructions for you to use the machine correctly and safely. To avoid injuries and financial loss, please carefully read this manual through before you start to operate the machine. And we kindly remind you to keep this manual properly for future reference.

All the information and illustrations in this document are for guidance only. 2M2 R&D Reserves the right to alter products designs, dimensions or info to improve the products quality. The contents of this document are fully protected by Copyright and may not be copied or reproduced in any form (e.g. mechanical, electronic, printing or video recording), without permission from Magic Star (Shenzhen) Technology Co., LTD.

2.2 Machine characteristics

- Smart control and operation on APP and build-in-database
- Portability and build-in Lithium battery with a long battery life (optional)
- Support clamps 2 in 1 (standard equipped)/HU64 (standard equipped)/FO21&TBE1 (optional)
- Supporting sided/track/dimple keys/tibbe keys/Motor keys
- Cutter and probe work in parallel
- Imported ball screw with high precision
- Cross rail with high rigidity
- Supporting online update
- Operating in multiple languages
- Note: Lithium battery is an optional accessory

3. Product packaging checklist

A full package of 2M2 Tank should include accessories listed in the following table. Please check when you get this product and contact your distributor if anything in the table is missing.

2M2

TANK automatic key cutting machine

Name	Picture	Quantity	Description
Machine		1	290*250*350mm Net weight:10.8kg
2.0mm cutter		2	Size:35*6*2mm Weight:14g Material:tungsten steel
1.5mm cutter		1	Size: 35*6*1.5mm weight:14g material:tungsten steel
Probe		4	Size:25*6*1.0mm Weight:10g Material: White steel
2.5mm hexagon wrench		1	Size:90*22*2.5mm Weight:4.5g Material: steel
8.0mm hexagon wrench		1	Size:80*40*8mm Weight:45.8g Material:steel
Stopper		1	Size:20*10.5*10mm Weight:4g Material:aluminium alloy

2M2

TANK automatic key cutting machine

Name	Picture	Quantity	Discription
Standard clamp		1	Size:120*42*30mm Weight:708g
HU64 clamp		1	Size:41*11*17mm Weight:12g
spanner (blue)		1	Size:155*35*3.5mm Weight:52g Material:steel
Spanner (red)		1	Size:155*35*3.5mm Weight:51.5g Material:steel
Brush		1	Size:135*25*5mm Weight:7.7g
Power adapter and wire		1	DC: 24V/5A Input:110-220V Size:210*82*40mm Weight:858g

Optional Accessories as beblow:

2M2

TANK automatic key cutting machine

Name	Pictures	Sample	Quantity	Discription
Super key blank S#			20pcs (per carton)	Length:51.5mm Witdh:7.8mm Thickness:3mm Weight:9.22g
Super key blank L#			20pcs (per carton)	Length:54mm Witdh:10mm Thickness:3m Weight:12.1g
Super key blank T#			20pcs (per carton)	Length:54mm Witdh:10mm Thickness:2mm Weight:9g
Built-in battery			1	Size:131*76*25mm Capacity:4500mah Weight:518g
FO21/TIBBE Clamp			1	Size:92*62*50mm weight:296g
Camera tool			2	Size:67*80*110mm weight:84g

4. Overview

2M2

TANK automatic key cutting machine



4.1 Specification

2M2

TANK automatic key cutting machine

Input voltage	110V ~ 220V
Input frequency	60/50Hz
Power	DC 24V/5A
Power parameter	200W
Battery capacity	4500mah
Principal axis rotation speed	10000rpm
Batter capacity	22V.90Wh
Working temperature	0-50°
Humidity	10-90%
Net weight	10.8KG
Gross weight	15.6KG
Machine size	25*29*35(CM)
Package size	49.8*43.5*49.8(CM)

4.2 software overview

2M2

TANK automatic key cutting machine

4.2.1 Introduction

- Supporting self-calibration
- Supporting key duplication and cutting for vehicle keys & motor keys
- Supporting universal key decode for multiple key types
- Operation on APP through Bluetooth
- Build-in key database

4.2.2 Smart phone operation system

- Android: Android 4.0 and above version

4.2.3 Software update

- Online update on APP

5. Installation

5.1 Install APP



Connection bluetooth

2M2

TANK automatic key cutting machine



At first, Plug machine into power supply, swith on the machine(LED lighting will be on)

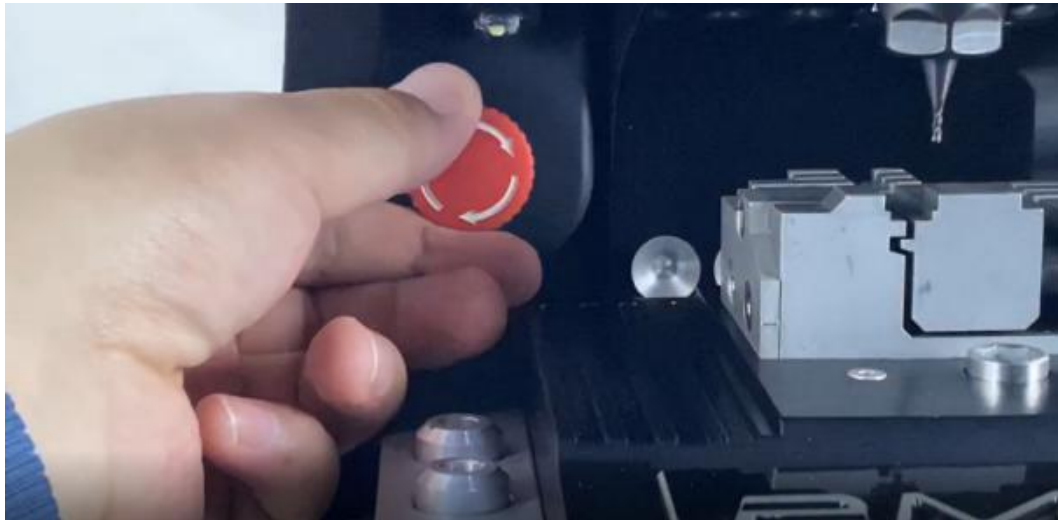

2M2

TANK automatic key cutting machine

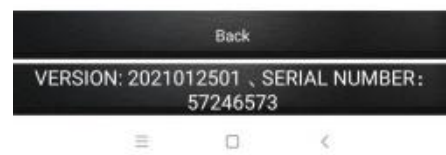
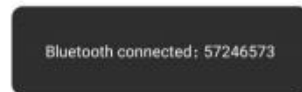

2M2

TANK automatic key cutting machine

5.2 Cutter and probe installation

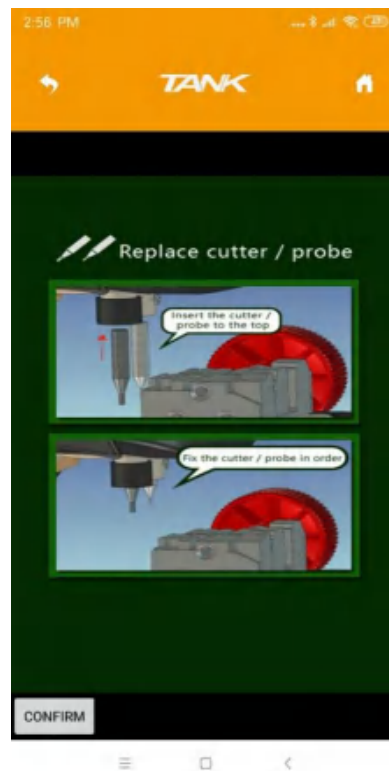
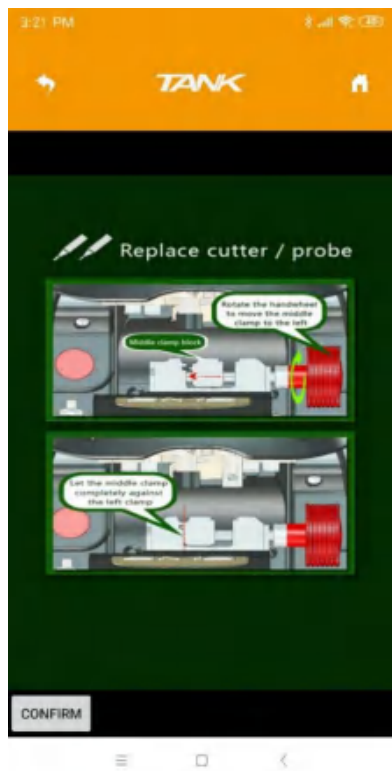

2M2

TANK automatic key cutting machine

Installation steps:

- 1) Put the cutter into the cutter mounting hole and push the cutter to the limit.
- 2) Push the probe into the probe mounting hole and finish operation depend upon APP guide.

Uninstallation steps:

- 1) Unscrew the locks for cutter and probe counter-clockwise until they are loosened off.
- 2) Take the cutter or probe off when it is loose.

5.3 clamp Introduction

- Pictures of clamp

Standard clamp(flat key & laser key,special keys HU162T, Toyota smart key)

Standard(flat) key



Laser key



2M2 standard 2 in 1 clamp

HU64 clamp



FO21&TIBBE clamp

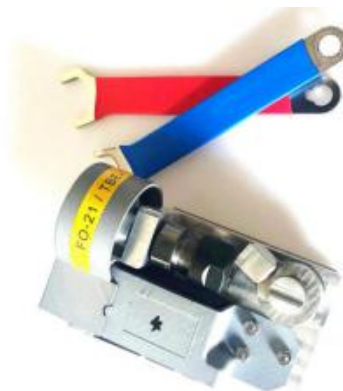

2M2

TANK automatic key cutting machine

5.4 Super key blank



5.5 Operation instructions on App

The system needs to initialize for first use. The steps as follows:

5.5.1 Install cutter & probe

2M2

TANK automatic key cutting machine



5.5.2 Calibration



5.5.3 Cut by biting

2M2

TANK automatic key cutting machine

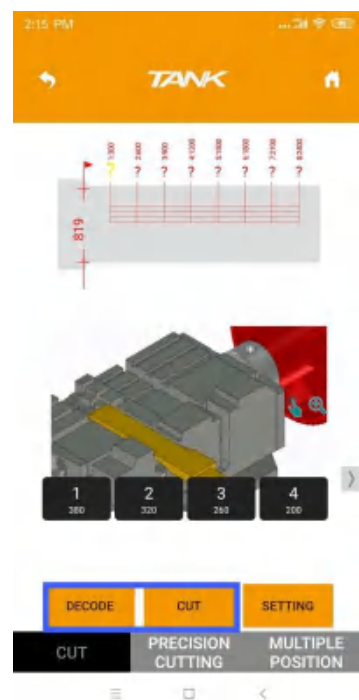
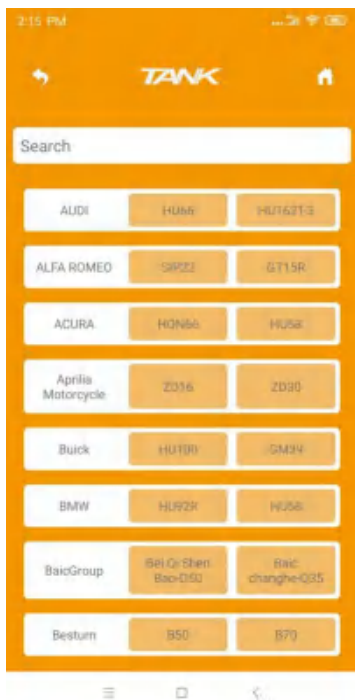
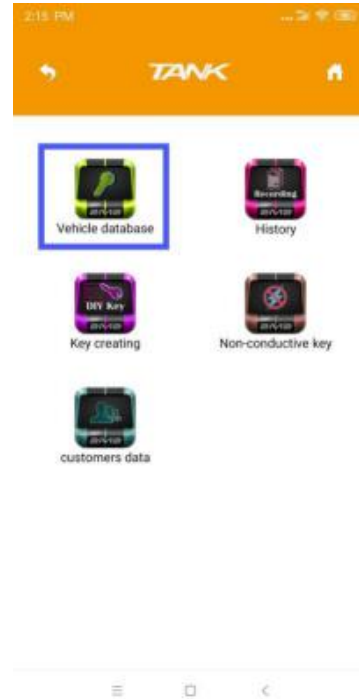

2M2

TANK automatic key cutting machine

5.5.4 All key lost

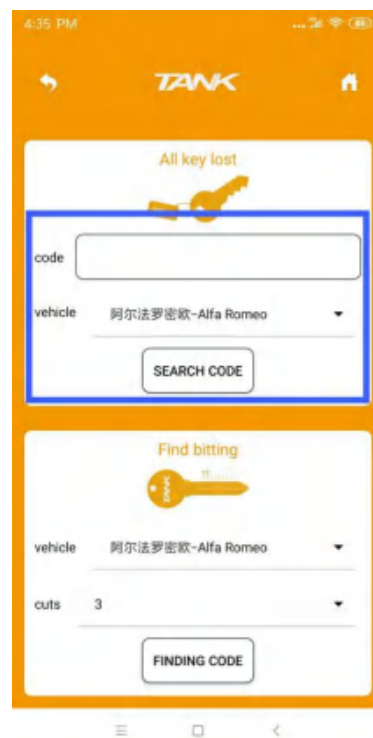

5.5.5 Find bitting

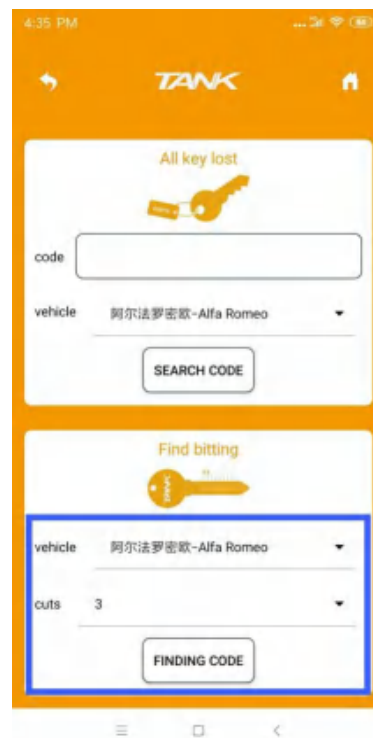

2M2

TANK automatic key cutting machine

5.5.6 Generate key type

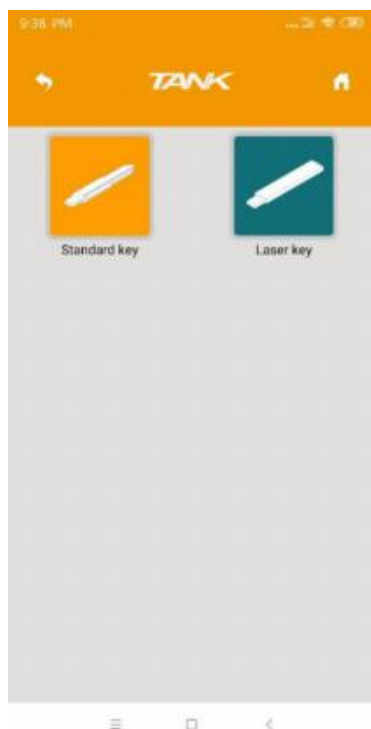
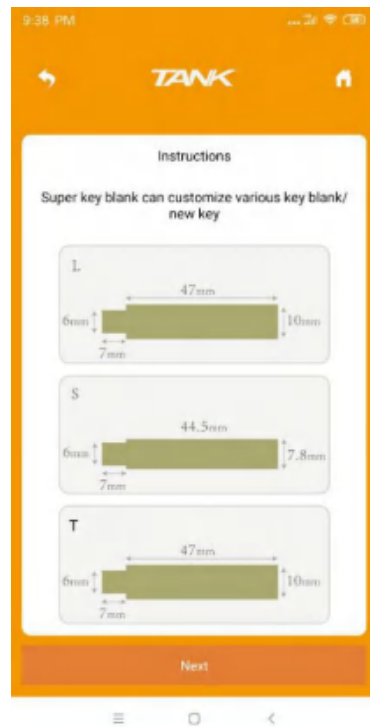

2M2

TANK automatic key cutting machine

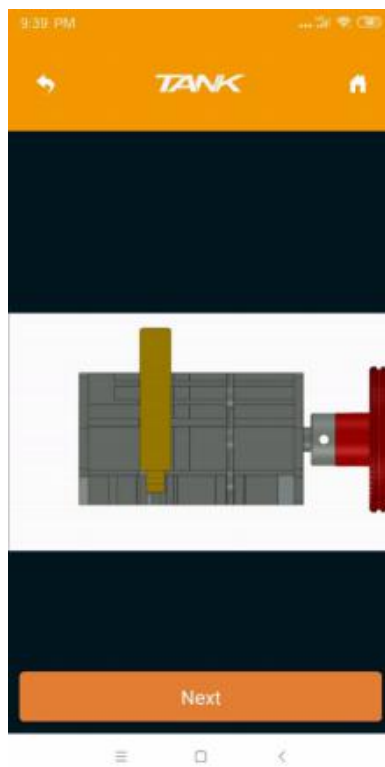
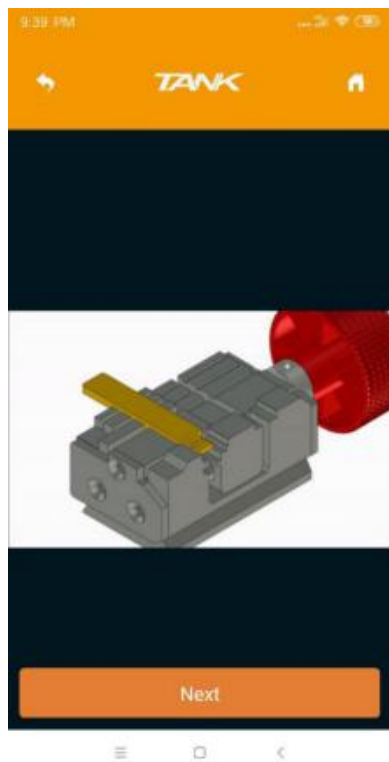
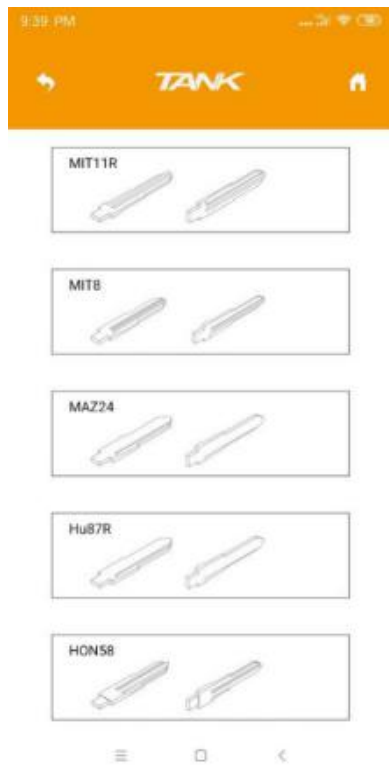

2M2

TANK automatic key cutting machine

5.5.7 Create keys by camera

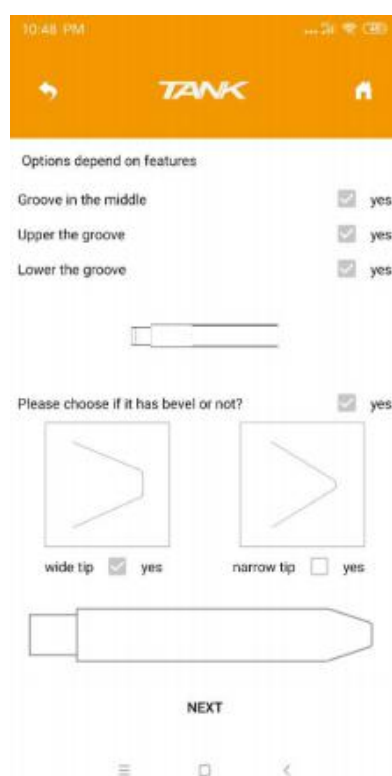
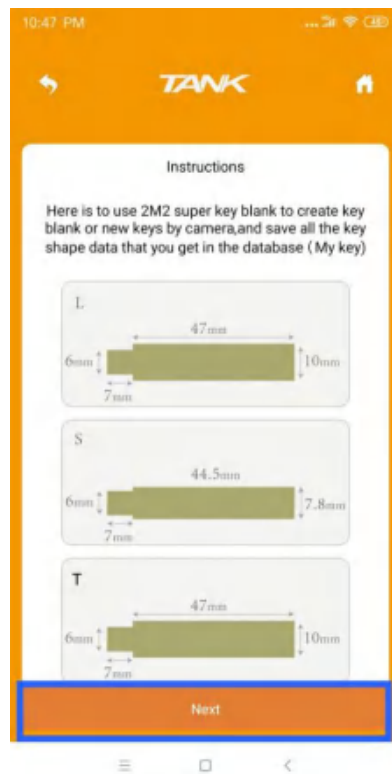

2M2

TANK automatic key cutting machine

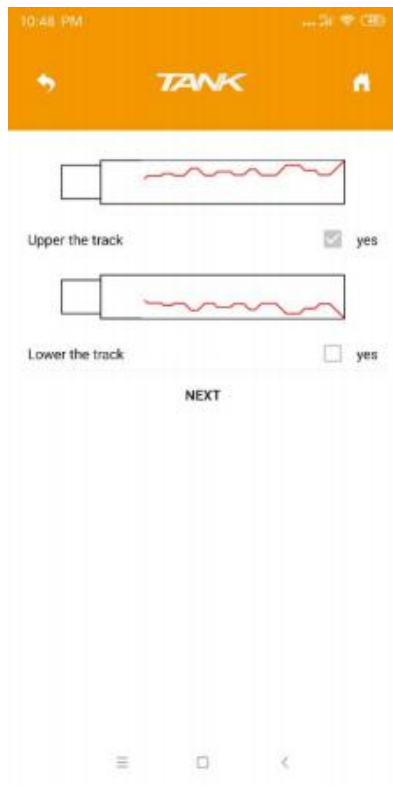

5.5.8 Customize key data



2M2

TANK automatic key cutting machine

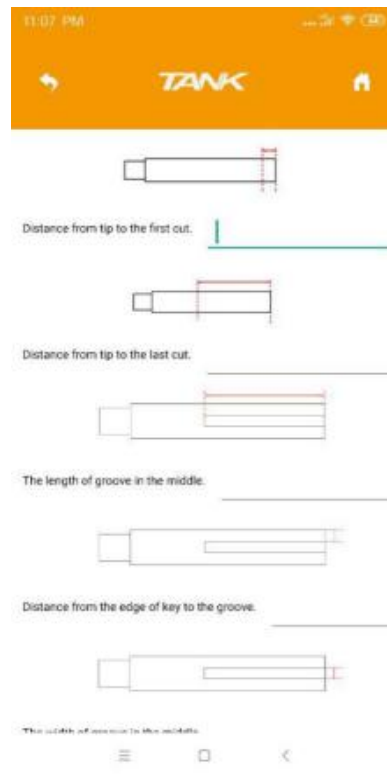
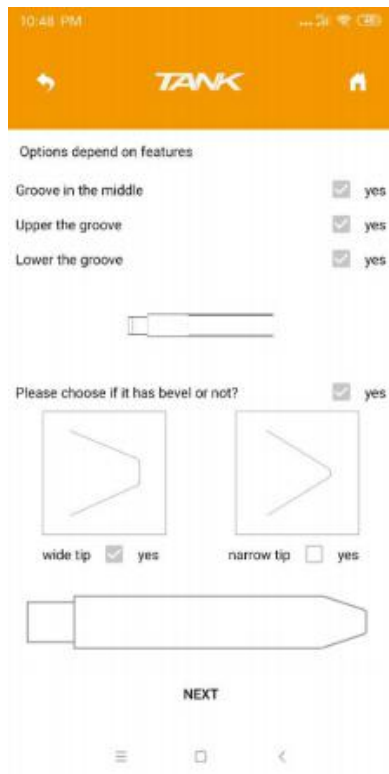

5.5.9 Universal key duplicate

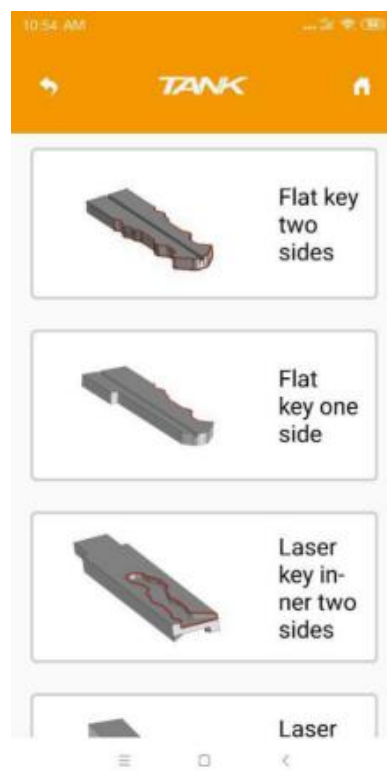

2M2

TANK automatic key cutting machine



5.6 Online update



App will update automatically if mobile phone connect the network.

Firmware will update automatically if mobile phone connect by bluetooth.5.7

2M2

TANK automatic key cutting machine

Maintenance

- Please clean the area around clamps with a brush before the machine starts to work. This is to assure cutting precision and avoid components damage by metal particles.
- To avoid damage or corrosion to the machine, please do not use detergent or other cleaning products to clean the machine.
- Please do not flush or wet the machine with water, in case rust and electrical current leakage.
- Under any circumstance, please do not try to clean the working area with air guns and drying machines, in case any metal carvings getting inside the machine.

5.8 Warranty and after-sale service

2M2 TANK key cutting machine has a warranty of 2 years for warranty. Any time if you have problem, only leave a message to the distributor or after sales service, we will try our best to solve the problem that you meet.

With warranty, free maintenance and repairing is not provided if the machine becomes dysfunctional due to the following reasons:

- Falling, knocking or wrong voltage
- Force majeure

5.9 After-sale service online

